

RESEARCH MANUSCRIPT

Analysis of five-parameter Viscoelastic model under Dynamic Loading

Rajneesh Kakar¹, K. Kaur² and K.C. Gupta²

¹Principal, DIPS Polytechnic College, Hoshiarpur-146001, India

²Faculty of Science, BMSCE, Muktsar-152026, India

rkakar_163@rediffmail.com; +91 9915716560

Abstract

The purpose of this study is to analysis the viscoelastic models under dynamic loading. A five-parameter model is chosen for study exhibits elastic, viscous, and retarded elastic response to shearing stress. The viscoelastic specimen is chosen which closely approximates the actual behaviour of a polymer. The module of elasticity and viscosity coefficients are assumed to be space dependent i.e. functions of 'x' in non-homogeneous case and stress-strain are harmonic functions of time 't'. The expression for relaxation time for five parameter viscoelastic model is obtained by using constitutive equation. The dispersion equation is obtained by using Ray techniques. The model is justified with the help of cyclic loading for maxima or minima.

Keywords: Shear waves, viscoelastic media, shearing stress, asymptotic method, dynamic loading.

Introduction

The vibrations in earthquakes are due to differences in dynamic characteristics therefore the cyclic stress-strain behaviour of material play a vital role for reliable prediction of the seismic response. Many researchers studied structural pounding during earthquakes. The lack of information concerns multi-dimensional waves in viscoelastic-media, and in particular for non-homogeneous media, therefore, a formal study of non-homogeneous viscoelastic models under dynamic loading is presented. Jankowski (2005) discussed the linear viscoelastic model and the nonlinear viscoelastic model. Anagnostopoulos (1988) studied the linear viscoelastic model of collision to simulate structural pounding. Jankowski *et al.* (1998) studied the pounding of superstructure segments in bridges with the help of linear viscoelastic model. Muthukumar and DesRoches (2006) made a comparison study using two single degree of freedom (SDOF) systems for capturing pounding. Westermo (1989) suggested linking buildings with beams which can transmit the forces between them eliminating dynamic contacts.

In this study, the module of elasticity and viscosity coefficients are assumed to be space dependent i.e. functions of 'x'. Further, shearing strain and stress are taken as harmonic functions of time 't' i.e. $\gamma = \gamma_0 e^{i\omega t}$ and $\sigma = G\gamma = G_0 \gamma_0 e^{i\omega t} = \sigma_0 e^{i\omega t}$. The expression for relaxation time for five parameter viscoelastic model is obtained by using constitutive equation. The dispersion equation is obtained by using Ray techniques. The model is justified with the help of cyclic loading for maxima or minima.

Methodology

The assumptions chosen are such that the conclusions drawn on the basis of which, agree quite reasonably and closely with the observed results of experimental tests. Following are the principal assumptions and hypothesis on which the problem has been constructed.

1. *Homogeneity*: The material of a structure to be considered should be homogeneous in structure and continuous at all points of the body. A homogeneous structure means that any how so ever small particle/portion of the body under consideration must possess the same properties. Among the materials that are considered to be homogeneous are metals, alloys, such as steel, aluminum, copper etc.
2. *Absolutely elastic*: The bodies considered being absolutely elastic with respect to deformation, when their deformations which appear due to external force, completely disappear upon removal of the load. Actually this holds true up to a definite value of load.
3. *Isotropy*: Material considered is taken to be isotropic, when it possesses the same characteristic in all directions. Isotropic materials include metals, concrete and some plastics. Materials possessing different properties in various directions are called an isotropic. Examples are wood, reinforced plastic etc.
4. *Infinite small deformations*: When deformations of elastic bodies, under the action of external loads, are small as compared with the dimensions of the bodies, i.e. the dimensions/shape are not changed substantially on elastic deformations. This assumption simplifies substantially the calculation, since it makes possible to neglect changes in the arrangement of the forces on deformation.

5. *Super-position-principle*: Since the deformation considered being small, it can be assumed that external forces act independently from one-another, i.e. the deformations and internal forces appearing inelastic bodies do not depend on the order in which the external forces are applied. Besides, it is assumed that the total effect of the whole system of forces acting on the body is the sum of the effects produced by individual forces.

About the model

It is a five parameter model with two springs $S_1(G_1), S_2(G_2)$ with module of elasticity G_1, G_2 and three dash pots $D_2(\eta_2'), D_1(\eta_1), D_3(\eta_3)$, with viscosities η_2', η_2, η_3 . It has three sections. Section I, Contains one spring $S_1(G_1)$, Section II contains three elements one spring $S_2(G_2)$ and two dash pots $D_2(\eta_2'), D_2(\eta_2)$ where the spring $S_2(G_2)$ and dash-pot $D_2(\eta_2)$ are in series forming Maxwell I-Model and the dash pot $D_2(\eta_2')$ is parallel to the Maxwell element. The section III contains only one dash-pot $D_3(\eta_3)$. The spring represents recoverable elastic response and dash pots represent elements in structure giving rise to the viscous drag/dissipative response (where the viscosity of the oil/fluid in the dash –pot decreases with the increase in temperature).

Section-I: Represented by only one spring $S_1(G_1)$ represents the elastic region (glassy), which is dominant at low temperatures. In this range of behavior of the material an applied stress (load) produces a strain, which is reversible upon the release of the stress under the elastic limits (instantaneous deformation). In case of polymer materials, the strain is due to the stretching of bonds within and between molecular chains. The chains, which are frozen to-gather initially, cannot flow past each other and may only be separated by fracture, which in our case does not happen as we are considering small-deformations. Thus the spring $S_1(G_1)$ represents the behavior of polymer in glass region.

Section-II: It represents leathery and rubbery region. In the leathery region, the modulus of elasticity drops rapidly with load (temperature) and reversible, sliding becomes possible in short segments of the chains of macromolecules. Small sections move and then cause the neighboring sections to move co-operatively. Here a transition appears between the elastic behaviors of Section I and viscoelastic behavior of Section II.

The reversibility of the movements of the short chain segments is expressed by the spring $S_2(G_2)$ in Section II and the resistance to this movement by the dash-pots $D_2(\eta_2')$ and $D_2(\eta_2)$. In the rubbery phase, the Viscoelastic behavior in section-II dominates the deformation. As the load increases, the molecular segments slide reversibly past one another and tend to straighten out in the direction of the load.

Section-III: This section is represented by a single dashpot $D_3(\eta_3)$, where permanent molecular sliding dominates the deformation process. At the higher loading, the viscosity decreases, due to internal fractions, which give rise to temperature increase and apparent modulus also drops, even to such an extent the material behaves as fluid as in the case of glaciers or melts, gels etc.

Middle section-II, Which is a series combination with a spring $S_1(G_1)$ of section-I and a dash-pot $D_3(\eta_3)$ section-III can be generated from Voigt Model by adding one more dash-pot to the spring side, so that it becomes a Maxwell-Model or it can be degenerated from a parallel combination of two Maxwell elements by detaching one spring from one of the Maxwell element i.e. taking the modulus of elasticity in this Maxwell element as infinitely greater i.e. $G \rightarrow \infty$. Since in section-II, the dash-pot $D_2(\eta_2')$ is free to flow as is not restricted by any spring so the model exhibits long term viscous flow. The Viscous element $D_2(\eta_2')$ and the Maxwell element ($D_2(\eta_2), S_2(G_2)$) possess this property. During relaxation the dash-pot $D_2(\eta_2')$, which is free from the restrictions of a spring will eventually take up the whole extension and stress will drop to zero slowly and ultimately.

It is further added that the combination/network of elastic elements (Spring $S(G)$) and viscous element (dashpots, $D(\eta)$), Maxwell-model, Voigt-Model is unidirectional i.e. all the elements lie in the same direction and all concerned forces and deformations act in this direction and are in the same plane.

Constitutive relation for five parameter model

The five parameter model consists of two springs $S_1(G_1), S_2(G_2)$, Where $G_1 = s_1 + 2\mu_1$ and $G_2 = s_2 + 2\mu_2$ are the module of elasticity associated to them and three dash-pots $D_2'(\eta_2'), D_2(\eta_2), D_3(\eta_3)$ where η_2', η_2, η_3 are the Newtonian Viscosity coefficients associates to these elements. The module of elasticity and viscosity coefficients are assumed to be space-dependent i.e. functions of 'x' in inhomogeneous case taken into consideration.

Unidirectional problem is formed by taking the material in the form of filament of non-homogeneous viscoelastic material by taking one end at $x = 0$. The co-ordinate x is measured positive in the direction of the axis of the filament. Time is specified by t , and σ, γ, u respectively, specify the only non-zero components of stress, shearing strain and particle displacement. The modal has been divided into three sections. Section I contains one spring $S_1(G_1)$ and section II contains two dash-pots $D_2'(\eta_2'), D_2(\eta_2)$ and one spring $S_2(G_2)$.

Fig. 1. Five parameter viscoelastic model.

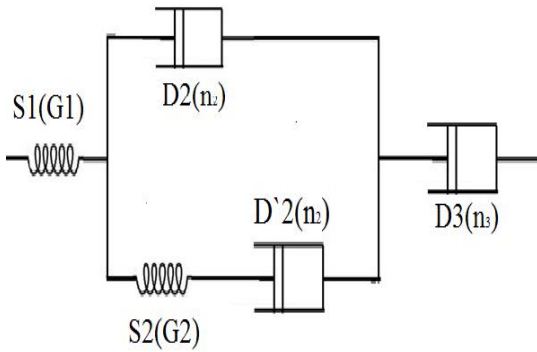

Section III contains one dash-pot $D_3(\eta_3)$. The network of connection of various dash-pots and springs is represented in figure 1. Under the superposition principle strains are added in the case of series connections and stresses are added when they are in parallel. Now if $\gamma_1, \gamma_2, \gamma_3$ be the three shearing strains in respective sections connected in series, then total elongation is given by

$$\gamma = \gamma_1 + \gamma_2 + \gamma_3 \tag{1}$$

The total Stress in the network remains the same. In each section, but in the case of section II which is sub-divided into two sections is added i.e. $\sigma = \sigma_1 + \sigma_2$, where σ_1 and σ_2 are the stresses in the sub-sections, as shown in figure 1. Relation for stress and strain for $D_2'(\eta_2)$ for section II is represented by single dash-pot.

$$\sigma_1 = \eta_2' \gamma_2 \tag{2}$$

Since the sub-section II_2 is represented by a Maxwell- element, then the relation is expressed as

$$\left(D(G_2) + \frac{1}{\eta_2} \right) \sigma_2 = D(\gamma_2) \tag{3}$$

Since, $\sigma = \sigma_1 + \sigma_2$ for Section II, therefore

$$\left(D(G_2) + \frac{1}{\eta_2} \right) \sigma = \sigma \left(1 + \left(\eta_2' \left(\frac{D}{G_2} + \frac{1}{\eta_2} \right) \right) \right) \tag{4}$$

For section I, for the Spring $S_1(G_1)$, the stress-strain relation is given by

$$\sigma = G_1 \gamma_1 \tag{5}$$

For section III; for the dash-pot $D_3(\eta_3)$, the stress-strain relation is given by

$$\sigma = \eta_3 \dot{\gamma}_3 \tag{6}$$

The stress-strain relation for the model representing the Viscoelastic body for total stress (σ) and strain (γ) can be obtained from Eq. (1), Eq. (4), Eq. (5) and Eq. (6) as:

$$\left[D^2 + \left\{ \frac{G_1}{\eta_2'} + \frac{G_1}{\eta_3} + \frac{G_2}{\eta_2'} + \frac{G_2}{\eta_2} \right\} D + \left\{ \frac{G_1 G_2}{\eta_2' \eta_2} + \frac{G_1}{\eta_3} \left(\frac{G_2}{\eta_2'} + \frac{G_2}{\eta_2} \right) \right\} \right] \sigma = G_1 \left\{ D^2 + \left(\frac{G_2}{\eta_2'} + \frac{G_2}{\eta_2} \right) D \right\} \gamma \tag{6}$$

Now we take $\tau_{ij}^{-1} = \theta_{ij} = \frac{G_i}{\eta_j} = \frac{S_i(G_i)}{Dj(\eta_j)}$ (7)

Where, $S_i(G_i)$, elastic modulus of spring and

$$Dj(\eta_j) = \text{viscosity of dash-pot, } \tau_{ij} = \frac{\eta_j}{G_i}, (i=1,2; j=2,2,3)$$

Using, Eq. (7) and Eq. (8), we get

$$\left[D^2 + \{ (\theta'_{12} + \theta_{13}) + (\theta_{22} + \theta'_{22}) \} D + (\theta'_{12} \cdot \theta_{22} + \theta_{13} (\theta_{22} + \theta'_{22})) \right] \sigma = G_1 \{ D^2 + (\theta_{22} + \theta'_{22}) D \} \gamma \tag{8}$$

Put $R_1 = \theta'_{12} + \theta_{13}$, $R_2 = \theta_{22} + \theta'_{22}$, $R_3 = \theta'_{12} \cdot \theta_{22}$ in Eq. (9), we get

$$\left[D^2 + (R_1 + R_2) D + (R_3 + \theta_{13} R_2) \right] \sigma = G_1 \{ D^2 + R_2 D \} \gamma = (G_1 D^2 + G_1 R_2 D) \gamma \tag{10}$$

The Eq. (10) can be written in terms of differential operator form as

$$\sum_{n=1}^2 \alpha_n b^n \gamma(x,t) = \sum_{m=0}^2 \beta_m D^m \sigma(x,t) \tag{11}$$

Where, the order m and n of sums on R.H.S and L.H.S in the relation (11) depends upon the structure of the mechanical model representing the viscoelastic body.

α_n and β_m are the combinations of the material constants and $\alpha_2 = G_1$, $\alpha_1 = G_1 R_2$, $\beta_2 = 1$, $\beta_1 = R_1 + R_2$, $\beta_0 = R_3 + \theta_{13} R_2$, $D \equiv \frac{d}{dt}$.

Eq. (11) is the required differential operator form of constitutive relation for the model for viscoelastic material to be studied.

Governing equations for viscoelastic model

One of the governing equation for the viscoelastic model is constitutive relation and is (11)

$$f(\sigma, \sigma_{,t}, \sigma_{,tt}, \gamma, \gamma_{,t}) = 0 \tag{9}$$

$$\beta_2 \sigma_{,tt} + \beta_1 \sigma_{,t} + \beta_0 \sigma = \alpha_2 \gamma_{,tt} + \alpha_1 \gamma_{,t} \tag{12a}$$



The equation of motion is

$$\sigma_{,x} = \rho u_{,tt} \text{ or } \left(\frac{1}{\rho} \sigma_{,x} \right) = \frac{1}{\rho} [\sigma_{,xx} - (\log \rho)_{,x} \sigma_{,x}] = \gamma_{,tt} \quad (13)$$

The displacement-strain relation is

$$\gamma = u_{,x} \quad (14)$$

The shearing stress field is

$$\beta_2 \sigma_{,ttt} + \beta_1 \sigma_{,tt} + \beta_0 \sigma_{,t} = \frac{\alpha_2}{\rho} \left\{ \sigma_{,xxt} - (\log \rho)_{,x} \sigma_{,xt} \right\} + \frac{\alpha_1}{\rho} \left\{ \sigma_{,xx} - (\log \rho)_{,x} \sigma_{,x} \right\} \quad (15)$$

Solution for five parameter viscoelastic model

We assume that the solution $\sigma(x, t)$ of Eq. (15) may be represented by the series

$$\sigma(x, t) = \sum_{n=0}^{\infty} A_n F_n(t-h(x)) = \sum_{n=0}^{\infty} A_n F_n(x),$$

$$x = t - h(x), A_n = 0, n < 0 \quad (16)$$

With, $F'_n = F_{n-1}, F_{n,x} = -h_{,x} F_{n-1}, F_{n,t} = F_{n-1},$
 $\sigma = A_n F_n, \sigma_{,t} = A_n F_{n-1}, \sigma_{,tt} = A_n F_{n-2}, \sigma_{,ttt} = A_n F_{n-3},$

The various derivatives stress with respect to x and t are

$$\sigma_{,x} = A'_n F_n - h_{,x} A_n F_{n-1},$$

$$\sigma_{,xx} = A''_n F_n - (2h_{,xx} A'_n + h_{,xx} A_n) F_{n-1} + A_n h_{,xx}^2 F_{n-2}$$

$$\sigma_{,xxt} = A''_n F_{n-1} - (2h_{,xx} A'_n + h_{,xx} A_n) F_{n-2} + A_n h_{,xx}^2 F_{n-3}$$

$$\sigma_{,xt} = A'_n F_{n-1} - h_{,x} A_n F_{n-2}, \quad (17)$$

From Eq. (16) and Eq. (17)

$$\beta_0 A_n F_{n-1} + \beta_1 A_n F_{n-2} + \beta_2 A_n F_{n-3} = \frac{\alpha_1}{\rho} \left\{ A''_n - (\log \rho)_{,x} A'_n \right\} F_n + \left[\frac{\alpha_1}{\rho} \left\{ \begin{matrix} h_{,x} (\log \rho)_{,x} A_n \\ - (2h_{,xx} A'_n + h_{,xx} A_n) \end{matrix} \right\} \right] F_{n-1} + \left[\frac{\alpha_1}{\rho} h_{,xx}^2 A_n \right] F_{n-2} + \frac{\alpha_2}{\rho} A_n h_{,xx}^2 F_{n-3} \quad (18)$$

Comparing the Coefficient of F_n , we get

$$\frac{\alpha_1}{\rho} \left\{ A''_n - (\log \rho)_{,x} A'_n \right\} = 0 \Rightarrow A''_n = (\log \rho)_{,x} A'_n \quad (19)$$

Comparing the Coefficient of F_{n-1} , we get

$$\beta_0 A_n = \left[\frac{\alpha_1}{\rho} \left\{ h_{,x} (\log \rho)_{,x} A_n - (2h_{,xx} A'_n + h_{,xx} A_n) \right\} + \frac{\alpha_2}{\rho} \left\{ A''_n - (\log \rho)_{,x} A'_n \right\} \right] \quad (20)$$

Comparing the coefficient of F_{n-2} , we get

$$\beta_1 A_n = \frac{\alpha_1}{\rho} h_{,xx}^2 A_n + \frac{\alpha_2}{\rho} \left\{ (\log \rho)_{,x} h_{,xx} A_n - (2h_{,xx} A'_n + h_{,xx} A_n) \right\} \quad (21)$$

Comparing the Coefficient of F_{n-3} , we get

$$\beta_2 A_n = \frac{\alpha_2}{\rho} A_n h_{,xx}^2 \quad (22)$$

Let, $\beta_2 = 1$ and $h_{,xx}^2 = \frac{\rho}{G_1}$ then Eq. (22) reduces to

$$h_{,xx}^2 = \frac{\rho}{\alpha_2} = \frac{\rho}{G_1} \quad (23)$$

From Eq. (19) and Eq. (21), we get

$$A_n \beta_1 = \frac{\alpha_1}{\rho} \left\{ h_{,x} (\log \rho)_{,x} A_n - (2h_{,xx} A'_n + h_{,xx} A_n) \right\} \quad (24)$$

From Eq. (21) and Eq. (24)

$$\left(\beta_1 - \frac{\alpha_1}{\rho} h_{,xx}^2 \right) \alpha_1 = \beta_1 \alpha_2 \Rightarrow \alpha_1 \beta_1 - \beta_1 \alpha_2 = \frac{\alpha_1}{\rho} h_{,xx}^2 \Rightarrow$$

$$\rho \left(\frac{\beta_1}{\alpha_1} - \frac{\alpha_2}{\alpha_1} \cdot \frac{\beta_1}{\alpha_1} \right) = h_{,xx}^2 = \frac{\rho}{G_1} \Rightarrow \frac{\beta_1}{\alpha_1} - \frac{\alpha_2}{\alpha_1} \cdot \frac{\beta_1}{\alpha_1} = \frac{1}{G_1} \quad (25)$$

From Eq. (20), we get

$$\beta_0 A_n = \frac{\alpha_1}{\rho} S \quad (26)$$

Where, $S = h_{,x} (\log \rho)_{,x} A_n - (2h_{,xx} A'_n + h_{,xx} A_n)$

From Eq. (12a), we get

$$\beta_1 A_n - \frac{\alpha_1}{\rho} h_{,xx}^2 A_n = \frac{\alpha_2}{\rho} S \quad (27)$$

From Eq. (26) and Eq. (27)

$$\beta_0 A_n \alpha_2 = \frac{\alpha_1 \alpha_2}{\rho} S \text{ and}$$

$$\left(\beta_1 A_n - \frac{\alpha_1}{\rho} h_{,xx}^2 A_n \right) \alpha_1 = \frac{\alpha_1 \alpha_2}{\rho} S.$$

Taking, $\beta_2 = 1, \alpha_2 = G_1, \alpha_1 = G_1 R_2, \beta_1 = R_1 + R_2$ and $R_3 + \theta_{13} R_2 = \beta_0$

$$\Rightarrow \beta_0 \alpha_2 = \beta_1 \alpha_1 - \frac{\alpha_1^2}{G_1} \text{ or } (R_3 + \theta_{13} R_2) G_1 =$$

$$G_1 R_2 (R_1 + R_2) - \frac{G_1^2}{G_1} R_2^2 \text{ and finally we get,}$$

$$R_1 R_2 = R_3 + \theta_{13} R_2 \tag{28}$$

Eq. (28) is the expression for relaxation time for five parameter viscoelastic model.

Dynamic loading

The time parameter 't' is introduced into an experimental scheme in dynamic experiments by cyclic deformation of the specimen. The frequency ' ω ' of the oscillations plays the role of the time factor. The cyclic deformation is the fundamental process of determining the mentioned characteristics. The greatest preference is given to harmonic oscillations. A Harmonic action of the stress/strain produces a corresponding harmonic response in the strain/stress. Let us consider that shearing strain (γ), induced in elastic body which can be expressed by a harmonic action as:

$$\gamma = \gamma_0 e^{i\omega t} \tag{29}$$

Where, γ_0 is the amplitude, ω is the frequency of oscillations and 't' is the time.

According to Hooke's Law, stress ' σ ' is

$$\sigma = G_0 \gamma = G_0 \gamma_0 e^{i\omega t} = \sigma_0 e^{i\omega t} \tag{30}$$

Where, $\sigma_0 = G_0 \gamma_0$, at t=0

For an elastic body, the strain and stress vary harmonically and there is no lack in the harmonic motion in phase as both have $e^{i\omega t}$ as a factor. Thus an elastic body responds instantaneously to the external action (strain/stress). The phase shift angle between strain and stress is zero. For an ideal viscous body, the Newton's Law of flow to a fluid body is as:

$$\sigma = \eta_0 D(\gamma) = \eta_0 \dot{\gamma} \Rightarrow \sigma = \eta_0 \gamma_0 i\omega e^{i\omega t} \tag{31}$$

Where, η_0 is the Viscosity of the body and

$$\eta_0 \gamma_0 \omega = \sigma_0 \text{ at } t=0$$

Thus, for a viscous deformation, stress advances by the strain by a phase angle $\frac{\pi}{2}$.

Thus, the phase shift angle for the stress-strain under periodic harmonic deformation for elastic body is $\frac{\pi}{2}$, also

for the viscous body, it is $\frac{\pi}{2}$. Therefore the phase shift angle ' δ ' for the viscoelastic body must be between zero and $\frac{\pi}{2}$ i.e. $0 < \delta < \frac{\pi}{2}$. The lagging in phase of the strain behind the stress is due to the presence of relaxation processes in the case of viscoelastic body, as phase shift angle δ , is given by $0 < \delta < \frac{\pi}{2}$.

Hence,

$$\gamma = \gamma_0 e^{i\omega t} \Rightarrow \sigma = \sigma_0 e^{i(\omega t + \delta)} \tag{32}$$

If we represent the projection of the stress vector on axis of co-ordinates by taking $\sigma' \leftrightarrow x$ and $\sigma'' \leftrightarrow y$, we write

$$\sigma = \sigma' + i \sigma'' \tag{33}$$

Where σ' and σ'' represent that real and imaginary parts respectively. If the strain is initially set harmonically, then the strain vector e^* coincides with its real part γ' and imaginary part $\gamma^* = \gamma''$

Then the modulus of Viscoelastic body with harmonic loading can be written as

$$\frac{\sigma^*}{\gamma^*} = \frac{\sigma'}{\gamma'} = \frac{\sigma'}{\gamma'} + i \frac{\sigma''}{\gamma'} = G' + iG'' = G^* \tag{34}$$

The phase angle ' δ ' is given as

$$\tan \delta = \frac{G''}{G'} \tag{35}$$

In the case of present model (Five-Parameter; two springs ($S_1 (G_1), S_2 (G_2)$); three dash-pots $D_2(\eta_2)$, $D_2(\eta_2)$, $D_3(\eta_3)$) which represents a linear viscoelastic behavior under a given action of loading, the stress is directly proportional to strain. This is also true for time dependent stress and strain relation i.e. for viscoelastic body, the stress is

$$\sigma(t) = G^* (i\omega)\gamma(t) = G^* \gamma_0 e^{i\omega t} \tag{36}$$

Where, $\gamma = \gamma_0 e^{i\omega t}$

Using, the relation $\sigma = G\gamma$ for an elastic body, the constitutive relation for the physical state representing the five parameter model is given by

$$D^2\sigma + (\alpha_1 + \alpha_2)D\sigma + (\alpha_3 + \alpha_4)\sigma = G_1(D^2 + \alpha_1D)\gamma \quad (37)$$

Where,

$$\alpha_1 = \theta_{13} + \theta'_{12}, \alpha_2 = \theta_{22} + \theta'_{22}, \alpha_3 = \alpha_2\theta_{13}, \alpha_4 = \theta'_{12}\theta_{22}$$

$$\text{Let, } G^* = G' + iG'' \quad (38)$$

Using Eq. (36), Eq. (37) and Eq. (38), we get

$$\begin{aligned} \{-\omega^2 + (\alpha_1 + \alpha_2)i\omega + (\alpha_3 + \alpha_4)\} G^* \gamma_0 e^{i\omega t} = \\ G_1(-\omega^2 + \alpha_2\omega i) \gamma_0 e^{i\omega t} \end{aligned} \quad (39)$$

On solving, we get

$$\begin{aligned} G^*(i\omega) &= \frac{G_1(-\omega^2 + \alpha_2\omega i)}{((\alpha_3 + \alpha_4 - \omega^2) + (\alpha_1 + \alpha_2)i\omega)} \\ G^*(i\omega) &= \frac{G_1(-\omega^2 + \alpha_2\omega i) [((\alpha_3 + \alpha_4 - \omega^2) - i(\alpha_1 + \alpha_2)i\omega)]}{A_1} \end{aligned} \quad (40)$$

$$\begin{aligned} G' + iG'' = G^*(i\omega) = \\ \frac{G_1 [\{\alpha_2(\alpha_1 + \alpha_2) - (\alpha_3 + \alpha_4) + \omega^2\} \omega^2 + \{\alpha_2(\alpha_3 + \alpha_4) + \alpha_1\omega^2\} i]}{A_1} \end{aligned} \quad (41)$$

Separate Eq. (41) into real and imaginary parts, we get

$$\begin{aligned} G' &= \frac{G_1 [\{\alpha_2(\alpha_1 + \alpha_2) - (\alpha_3 + \alpha_4) + \omega^2\} \omega^2]}{A_1} \\ G'' &= \frac{G_1 [\{\alpha_2(\alpha_3 + \alpha_4) + \alpha_1\omega^2\} \omega]}{A_1} \end{aligned} \quad (42)$$

And Loss tangent is given by

$$\begin{aligned} \text{Tan } \delta = \frac{G''}{G'} = \frac{\alpha_2(\alpha_3 + \alpha_4) + \alpha_1\omega^2}{\omega \{ \alpha_2(\alpha_1 + \alpha_2) - (\alpha_3 + \alpha_4) + \omega^2 \}} = \\ \frac{\alpha_2(\alpha_3 + \alpha_4) + \alpha_1\omega^2}{\omega [\omega^2 - \{(\alpha_3 + \alpha_4) - \alpha_{2(\alpha_1 + \alpha_2)}\}]} \end{aligned} \quad (43)$$

To find the values of G'' , we put

$$G'' = G_1 \frac{A\omega + B\omega^2}{(c - \omega^2)^2 + D^2\omega^2} \quad (44)$$

Where,

$$A = \alpha_2(\alpha_3 + \alpha_4), B = \alpha_1, C = \alpha_3 + \alpha_4, D = \alpha_1 + \alpha_2,$$

$$A_1 = (c - \omega^2)^2 + D^2\omega^2$$

$$\text{Now } D'(G''(i\omega)) = 0 \quad (45)$$

With the help of Eq. (45), the dispersion relation can be derived (calculations are shown in the appendix)

$$\omega^6 - \left\{ D^2 - \left(3\frac{A}{B} + 2C \right) \right\} \omega^4 + \left\{ \frac{A}{B} D^2 - \left(2\frac{A}{B} + 3C \right) C \right\} \omega^2 - \frac{AC^2}{B} = 0 \quad (46)$$

Where,

$$A = \alpha_2(\alpha_3 + \alpha_4), B = \alpha_1, C = \alpha_3 + \alpha_4, D = \alpha_1 + \alpha_2,$$

$$A_1 = (c - \omega^2)^2 + D^2\omega^2 \quad (47)$$

Equation (46) gives the dispersion equation for wave propagation. It is a cubic in ω^2 , giving three roots, it must have one real root as complex roots always occur in conjugate pairs or all three roots are real, for G'' has either a maximal value or minimum value. Therefore, taking roots as $\omega_1^2, \omega_2^2, \omega_3^2$, we get

Sum of roots,

$$\omega_1^2 + \omega_2^2 + \omega_3^2 = D^2 - \left(3\frac{A}{B} + 2C \right) \quad (48)$$

Product of roots taken two at a time,

$$\omega_1^2\omega_2^2 + \omega_2^2\omega_3^2 + \omega_3^2\omega_1^2 = \frac{A}{B} D^2 - \left(2\frac{A}{B} + 3C \right) C \quad (49)$$

Products of roots,

$$\omega_1^2\omega_2^2\omega_3^2 = \frac{AC^2}{B} \quad (50)$$

To determine $\omega_1^2, \omega_2^2, \omega_3^2$ through relation (47) seems not to be so easy, but if we observe carefully the value of G'' , we can conclude about the roots $\omega_1^2, \omega_2^2, \omega_3^2$, as follows (see appendix):

$$G'' = G_1 \frac{\{\alpha_2(\alpha_3 + \alpha_4)\omega + \alpha_1\omega^2\} \omega}{(\alpha_3 + \alpha_4 - \omega^2)^2 + (\alpha_1 + \alpha_2)^2\omega^2} \quad (51)$$



To find the other two roots ω_2^2, ω_3^2 for the Eq. (46) from Eq. (48), Eq. (49) and Eq. (50), such that (Taking one of the values for $\omega_1^2, \omega_2^2, \omega_3^2$ for the extreme values of G'' as $\omega_1^2 = C$)

$$\omega_2^2 + \omega_3^2 = D^2 - 3\left(\frac{A}{B} + C\right), \omega_2^2 \cdot \omega_3^2 = \frac{AC}{B}$$

Then Eq. (46) can be expressed as

$$x^2 - \left(D^2 - 3\left(\frac{A}{B} + C\right)\right)x + \frac{AC}{B} = 0$$

We get the roots,

$$\omega_2^2 = \frac{AC}{B\left(D^2 - 3\left(\frac{A}{B} + C\right)\right)} = \frac{AC}{BD^2 - 3(A + BC)} \quad (52)$$

$$\omega_3^2 = \frac{AC}{B\omega_2^2} = \frac{BD^2 - 3(A + BC)}{B} \quad (53)$$

Where,

$$A = \alpha_2(\alpha_3 + \alpha_4) = (\theta_{22} + \theta'_{22})(\theta_{13}\alpha_2 + \theta'_{12}\theta_{22}) = \left[\frac{G_2 + G_2}{\eta_2 + \eta'_2}\right] \left[\frac{G_1}{\eta'_2} \cdot \frac{G_2}{\eta_2} + \frac{G_1}{\eta_3} \left(\frac{G_2 + G_2}{\eta_2 + \eta'_2}\right)\right]$$

$$B = \alpha_1 = \theta_{13} + \theta'_{12} = \frac{G_1}{\eta_3} + \frac{G_1}{\eta'_2}$$

$$C = \alpha_3 + \alpha_4 = \theta_{13}\alpha_2 + \theta'_{12}\theta_{22} = \frac{G_1}{\eta_3} \left(\frac{G_2 + G_2}{\eta_2 + \eta'_2}\right) + \frac{G_1}{\eta'_2} \cdot \frac{G_2}{\eta_2}$$

$$D = \alpha_1 + \alpha_2 = \theta_{13} + \theta'_{12} + (\theta_{22} + \theta'_{22}) = \frac{G_1}{\eta_3} + \frac{G_1}{\eta'_2} + \frac{G_2}{\eta_2} + \frac{G_2}{\eta'_2} \quad (54)$$

Error due to approximation is

$$4AC \ll B\left(D^2 - 3\left(\frac{A}{B} + C\right)\right) \quad (55)$$

Using Eq. (49), Eq. (50) and Eq. (48), one can find

$$\omega_1^2 = C, \omega_2^2 = \frac{AC}{\{D^2B - 3(A + BC)\}}, \omega_3^2 = \{BD^2 - 3(A + BC)\} / B.$$

From, Eq. (49)

$$\omega_1^2 \omega_2^2 + \omega_2^2 \omega_3^2 + \omega_3^2 \omega_1^2 = \frac{A}{B} D^2 - \left(2\frac{A}{B} + 3C\right)C = \frac{AD^2 - (2A + 3BC)C}{B} \quad (56)$$

Approximate value

$$\omega_1^2 \omega_2^2 + \omega_2^2 \omega_3^2 + \omega_3^2 \omega_1^2 = \frac{AC^2}{\{D^2B - 3(A + BC)\}} + \frac{AC}{B} + \frac{C}{B}\{D^2B - 3(A + BC)\} \quad (57)$$

Error can be calculated by subtracting Eq. (56) and Eq. (57)

$$\text{Error } (\xi) = \frac{A}{B} D^2 -$$

$$\frac{3(A + BC)C}{B} - \frac{AC^2}{\{D^2B - 3(A + BC)\}} - \frac{C}{B}\{D^2B - 3(A + BC)\}$$

$$\therefore (\xi) = \frac{1}{B}\{AD^2 - 3(A + BC)C\} - \frac{C}{B} \frac{[ABC + \{D^2B - 3(A + BC)\}^2]}{D^2B - 3(A + BC)}$$

Taking the +ve sign, we get

$$\omega_3^2 = \frac{1}{B}\{D^2B - 3(A + BC)\} \left[1 - \frac{ACB}{\{D^2B - 3(A + BC)\}^2}\right]$$

$$\Rightarrow \omega_3^2 = \frac{1}{B}\{D^2B - 3(A + BC)\} - \frac{AC}{D^2B - 3(A + BC)}$$

Case-1

At very low frequencies, $\omega = 0$, (from Eq. (51))

$$G''(\omega = 0) = 0, G''\left(\omega^2 = -\frac{\alpha_2(\alpha_3 + \alpha_4)}{\alpha_1}\right) = 0 \quad (58)$$

Then, it is to be inferred that during the cyclic loading initially $\omega = 0 \Rightarrow G''(0) = 0$ i.e. there must be a point of maxima or minima between $\omega = 0$ and $\omega = -\frac{\alpha_2(\alpha_3 + \alpha_4)}{\alpha_1}$

Case-2

At very high frequencies, $\omega = \infty$ (from Eq. (51))

$$G''(\infty) = 0 \quad (59)$$

Then it is to be inferred that during the cyclic loading initially $\omega = 0 \Rightarrow G''(0) = 0$ i.e. there must be a point of maxima or minima between $\omega = 0$ and $\omega = -\frac{\alpha_2(\alpha_3 + \alpha_4)}{\alpha_1}$

but for $\omega^2 = \alpha_3 + \alpha_4$ it is observed that for $\omega^2 = C$ there must be a point of maxima as when initially $G''(0)$ increases from zero to maximum value $G_m^* = \frac{G_1\sqrt{(\alpha_3 + \alpha_4)}}{(\alpha_1 + \alpha_2)}$

and again states that diminishing and reaches zero at $\omega^2 = -\frac{\alpha_2(\alpha_3 + \alpha_4)}{\alpha_1}$, which justifies for the model for the

Viscoelastic materials.

Loading of the model

When relaxation is applied to the model i.e. the model is under the influence the constant deformation, the specimen representing the model is deformed to the given strain γ_0 and after which it is maintained constant, where as the stress required to maintained these strains (γ_0) diminishes at $e = \gamma_0$ constant, under thermal conditions. The Constitutive equation under constant deformation (strain) $e = \gamma_0$ constant reduces to

$$D^2\sigma + B_1D\sigma + B_0\sigma = 0 \tag{60}$$

Where,

$$B_1 = (\theta_{13} + \theta'_{12}) + (\theta_{22} + \theta'_{22}), B_0 = \theta'_{12}\theta_{22} + \theta_{13}(\theta_{22} + \theta'_{22}).$$

Eq. (60) can be solved, we taking the roots of the auxiliary equation as

$$m_1 = \frac{1}{\tau_1} \quad \text{and} \quad m_2 = \frac{1}{\tau_2} \tag{61}$$

Where, τ_1 and τ_2 are relaxation times of the specimen.

$$\therefore m_1 m_2 = \frac{1}{\tau_1} \cdot \frac{1}{\tau_2} = \theta'_{12}\theta_{22} + \theta_{13}(\theta_{22} + \theta'_{22}) \tag{62}$$

From, Eq. (62), the Eq. (60) becomes

$$\{D^2 + (m_1 + m_2)D + (m_1 m_2)\}\sigma = 0 \tag{63}$$

The Solution of Eq. (63) is

$$\sigma(t) = A_1 e^{-m_1 t} + A_2 e^{-m_2 t} \tag{64}$$

To eliminate A_1 and A_2

$$\text{At, } t=0, \text{ Eq. (64) reduces to } \sigma_0 = \gamma_0 G, \frac{d\gamma_0}{dt} = 0$$

Hence,

$$A_1 + A_2 = \sigma_0 \tag{65}$$

$$m_1 A_1 + m_2 A_2 = 0 \tag{66}$$

Where,

$$A_1 = \frac{m_2 \sigma_0}{m_2 - m_1}, A_2 = \frac{m_1 \sigma_0}{m_1 - m_2}$$

$$\therefore \sigma(t) = \frac{\sigma_0}{m_1 - m_2} \{m_1 e^{-m_2 t} - m_2 e^{-m_1 t}\} = \frac{G_0 \gamma_0}{m_1 - m_2} \{m_1 e^{-m_2 t} - m_2 e^{-m_1 t}\}$$

For sufficiently large time, $t > \tau_1, \tau_2$ so that $\sigma \rightarrow 0$.

Hence, with longer periods of observation, the stress in the specimen will drop to zero, i.e. equilibrium state will be achieved.

Conclusion

From the above study, the following conclusions can be done:

During the cyclic loading initially there must be a point of maxima or minima between $\omega = 0$ and

$$\omega = -\frac{\alpha_2(\alpha_3 + \alpha_4)}{\alpha_1}.$$

1. For sufficiently large relaxation time, the stress in the specimen will drop to zero.
2. The phase shift angle ' δ ' for the viscoelastic body must be between zero and $\frac{\pi}{2}$.

Acknowledgements

The authors are thankful to the referees for their valuable comments.

References

1. Anagnostopoulos, S.A. 1988. Pounding of buildings in series during earthquakes. *Earthquake Engg. Structural Dynamics*. 16(3): 443-456.
2. Jankowski, R., Wilde, K. and Fujino, Y. 1998. Pounding of superstructure segments in isolated elevated bridge during earthquakes. *Earthquake Engg. Structural Dynamics*. 27: 487-502.
3. Muthukumar, S. And Desroches, R. 2006. A Hertz contact model with nonlinear damping for pounding simulation. *Earthquake Engg. Structural Dynamics*. 35: 811-828.
4. Westermo, B.D. 1989. The dynamics of interstructural connection to prevent pounding. *Earthquake Engg. Structural Dynamics*. 18: 687-699.
5. Jankowski, R. 2005. Non-linear viscoelastic modelling of earthquake-induced structural pounding. *Earthquake Engg. Structural Dynamics*. 34(6): 595-611.

Appendix

$$D^*(G^*(i\omega)) = \frac{G_1 [(A+3B\omega^2)A_1 - (A\omega+B\omega^2)(A_1) \{-2.2\omega(c-\omega^2+2D^2\omega)\}]}{A_1^2}$$

$$(A+3B\omega^2)A_1 - 2\omega^2(A+B\omega^2)\{(D^2-2c)+2\omega^2\} = 0$$

$$(A+3B\omega^2)\{(c-\omega^2)^2 + D^2\omega^2\} - 2\omega^2(A+B\omega^2)\{(D^2-2c)+2\omega^2\} = 0$$

$$(A+3B\omega^2)\{C^2 + \omega^4 + (D^2-2c)\omega^2\} - 2\omega^2[A(D^2-2c) + \{2A+B(D^2-2c)\}\omega^2 + 2B\omega^4] = 0$$

$$AC^2 + \{3BC^2 - A(D^2-2c)\}\omega^2 + \{-3A+BCD^2-2C\}\omega^4 - B\omega^6 = 0$$

$$G^*(\omega^2 = \alpha_3 + \alpha_4) = \frac{G_1 \{\alpha_2(\alpha_3 + \alpha_4) + \alpha_1(\alpha_3 + \alpha_4)\} \sqrt{(\alpha_3 + \alpha_4)}}{(\alpha_1 + \alpha_2)^2 (\alpha_3 + \alpha_4)}$$

$$G^*(\omega^2 = \alpha_3 + \alpha_4) = \frac{G_1 \sqrt{(\alpha_3 + \alpha_4)}}{(\alpha_1 + \alpha_2)}$$

m_1, m_2 are the roots of the equation

$$x^2 - (\theta_{13} + \theta'_{12} + \theta_{22} + \theta'_{22})x + (\theta'_{12}\theta_{22} + \theta_{13}(\theta_{22} + \theta'_{22})) = 0$$

$$x = \frac{1}{2} \left(D^2 - 3\left(\frac{A}{B} + C\right) \right) \pm \sqrt{D^2 - 3\left(\frac{A}{B} + C\right)^2 - \frac{4AC}{B}}$$

$$\omega_3^2 \omega_4^2 = \frac{1}{2} \left(D^2 - 3\left(\frac{A}{B} + C\right) \right) \left[1 \pm \sqrt{1 - \frac{\frac{2AC}{B}}{\left(D^2 - 3\left(\frac{A}{B} + C\right) \right)^2}} \right]$$